

Model 202 Ozone Monitor™

EPA Federal Equivalent Method (FEM)



The 2B Technologies Model 202 Ozone Monitor™ is designed to enable accurate and precise measurements of ozone ranging from low ppb (precision of ~1.5 ppb) up to 250,000 ppb (250 ppm) based on the well-established technique of absorption of UV light at 254 nm. The Model 202 Ozone Monitor™ is lightweight (5.5 lb, 2.5 kg) and has a low power consumption (12V DC, 0.60 amp, ~7.2 watt) relative to conventional instruments and is therefore well suited for applications such as:

- Vertical profiling using balloons, kites, RPVs, and light aircraft where space and weight are highly limited
- Long-term monitoring at remote locations where power is highly limited
- Urban arrays of ground-based detectors
- Personal exposure monitoring for studies of health effects of air pollutants
- Environmental health and safety monitoring
- Laboratory studies of the effects of ozone exposure on materials and organisms

Flash memory (SD card) and a quiet long-life internal air pump are now provided as standard features on the Model 202.

The Model 202 has been designated by the EPA as a Federal Equivalent Method (FEM): [EQOA-0410-190](#). As a designated FEM, the Model 202 Ozone Monitor may be used by states and other monitoring agencies under 40 CFR Part 58, Ambient Air Quality Surveillance, for monitoring for compliance with the Clean Air Act.

2B Technologies, 6800 W. 117th Avenue, Broomfield, Colorado 80020, USA

Schematic Diagram

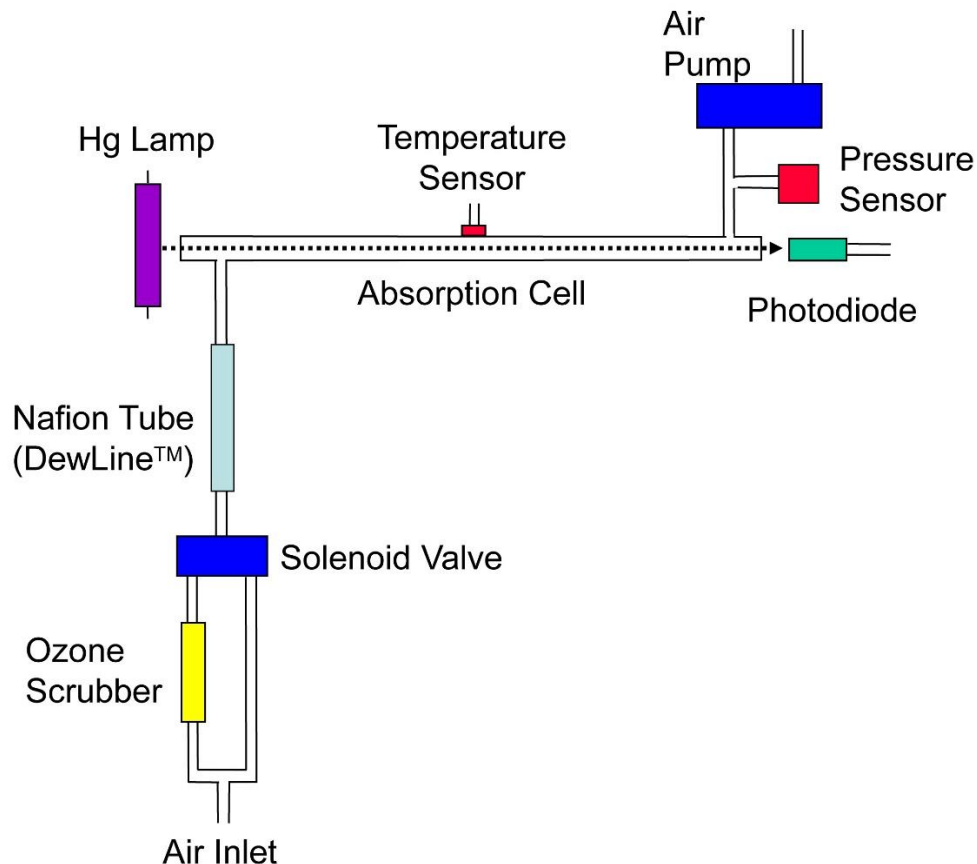

Features

- Quiet, long-life internal air sampling pump
- Low power consumption: ~7.2 watts
- Internal data logger (EEPROM), logs 16,383 lines of data
- Real-time clock
- Both serial and user-scalable analog voltage outputs (4-20 mA current output optional)
- Flash card memory (SD card) for virtually unlimited, portable data storage
- Three 0-2.5 VDC analog inputs for logging other measurements, such as external temperature, pressure, and humidity
- Convenient user interface to microprocessor, including calibration parameters (gain and zero)
- Selectable measurement time of 10 s or data averaging times of 1 min, 5 min and 1 hr (custom averaging times available)
- Selectable units for ozone, pressure, and temperature
- DewLine™ for elimination of any water vapor interference, a unique feature of 2B Tech instruments

2B Technologies, 6800 W. 117th Avenue, Broomfield, Colorado 80020, USA

Options

- GPS for continuous logging of latitude, longitude, and altitude
- Rechargeable lithium-ion battery provides ~12 hours of continuous operation
- External particle filter
- Bluetooth for wireless data transmission
- 4-20 mA analog current output
- Serial-to-USB converter
- Cold-weather package (pump, lamp heater for use down to -20°C)
- High-altitude upgrade (pressure sensor for use up to 25 km altitude)
- Low-power option for even lower power consumption
- Extra long-life, low-temperature internal air pump
- Rack-mount case configuration

Specifications

Measurement Principle	UV Absorption at 254 nm
Federal Equivalent Method (FEM)	Yes, EQOA-0410-190
Linear Dynamic Range	0 ppb to 250 ppm
Resolution	0.1 ppb
Precision (1σ; rms noise)	Greater of 1.5 ppb or 2% of reading (in 10-s measurement mode)
Limit of Detection (2σ)	3.0 ppb (in 10-s measurement mode)
Accuracy	Greater of 1.5 ppb or 2% of reading
NIST-Traceable Calibration	Yes
Measurement Interval	10 s (Data averaging options: 1 min, 5 min, 1 hr)
Flow Rate (nominal)	~1 Liter/min
Flow Rate Requirement	>0.6 L/min
Baseline Drift	<2 ppb/day <5 ppb/year
Sensitivity Drift	<1%/day <3%/year
Measurement Time, Frequency	10 s, 0.1 Hz
Response Time, 100% of Step Change	20 s, 2 points
Averaging Times	1 min, 5 min, 1 hr
Ozone Units	ppb, pphm, ppm, $\mu\text{g m}^{-3}$, mg m^{-3}
Pressure Units	mbar, torr
Temperature Units	°C, K

2B Technologies, 6800 W. 117th Avenue, Broomfield, Colorado 80020, USA

T and P Corrected	Yes
Operating Temperature Range	0 to 50°C standard; optional -20 to 50°C with low temperature modifications (pump and lamp heater cold-weather package)
Operating Altitude Range	~0-13.5 km (150-1,013 mbar) standard; optional ~0-25 km (30-1,013 mbar) with upgraded pressure sensor
Power Requirement; Supplied by battery or 110/220 VAC Power Pack	11-14 V DC or 120/240 VAC, nominally 600 mA at 12 V, 7.2 watt (6.2 watt with cell heater unplugged)
Size	3.7 x 8.5 x 11.8 inches (9.5 x 21.5 x 30 cm)
Weight	5.5 lb (2.5 kg); 2.8 lb (1.3 kg) without instrument case
Internal Data Logger Capacity	16,383 lines (10-s measurement mode = 1.9 days; 1-min avg = 11 days; 5-min avg = 1.9 mo; 1-hr avg = 1.9 yr)
SD Card Logger Capacity	Minimum 2 GB (> 5-year capacity for 10-s measurement mode)
Analog Inputs for Internal Logging of Other Instruments	3 Analog Inputs, 0-2.5 V (for example could log external T, P, and RH)
Data Outputs	RS232, 0-2.5 V Analog, LCD Display (Options: 4-20 mA Analog Current Output; Request Quote)
Data Transfer Baud Rates	2400, 4800, 19200
Output Ranges	User-Defined Scaling Factor in Menu
DewLine™	Yes
Quiet, Long-Life Internal Air Pump	Yes
Flow Meter	Yes
Options	Battery; External Particle Filter, Serial-to-USB Converter; Bluetooth; 4-20 mA Current Output; GPS; Cold-Weather Package, -20 to 50°C (pump, lamp heater); High-Altitude Upgrade (~0 to 25 km); Low-Power Option; Extra-Long-Life Internal Air Pump; Rack-Mount Case Configuration
Upgradable to Model 205 Dual Beam	Yes

System Includes

- Model 202 Ozone Monitor with quiet, long-life internal air pump
- AC Power Adapter (100-240 VAC to 12 VDC) with Country-Specific Plug
- Zeroing Cartridge
- Flash Card Memory for virtually unlimited, portable data storage
- SD Card (minimum 2 GB) and SD Card Reader
- Operation Manual on USB Stick
- Calibration Data and NIST-Traceable Calibration Certificate
- Instrument Birth Certificate
- One-Year Warranty

2B Technologies, 6800 W. 117th Avenue, Broomfield, Colorado 80020, USA