

Model 205 Dual Beam Ozone Monitor™

EPA Federal Equivalent Method (FEM)



The Model 205 Dual Beam Ozone Monitor makes use of two detection cells to improve precision, baseline stability, and response time. In the Dual Beam instrument, UV light intensity measurements I_0 (ozone-scrubbed air) and I (unscrubbed air) are made simultaneously. Combined with other improvements, this made it possible to reduce the time between ozone measurements to 2 seconds, making our instrument the fastest UV-based ozone monitor on the market, while still retaining the small size, weight, and power requirements of our popular Model 202 Ozone Monitor. Fast measurements are especially desirable for aircraft and balloon measurements where high spatial resolution is desired. Alternatively, one can choose to average more points internally to obtain even better precision.

The Model 205 has all of the features of the Model 202, including choice of measurement or averaging time (2 s, 10 s, 1 min, 5 min, 1 hr), analog output (0-2.5 V), real time serial output, internal data logger with 3 analog inputs for simultaneous logging of other measurements (e.g., T, P, and RH), and real-time clock. Flash memory (SD card) and quiet long-life internal pump are now standard features.

The Model 205 Dual Beam Ozone Monitor is an Environmental Protection Agency (EPA) Federal Equivalent Method (FEM): [EQQA-0410-190](#).

Phone: +1(303)273-0559, Fax: +1(303)-277-1812, www.twobtech.com

2B Technologies, 6800 W. 117th Avenue, Broomfield, Colorado 80020, USA

Schematic Diagram

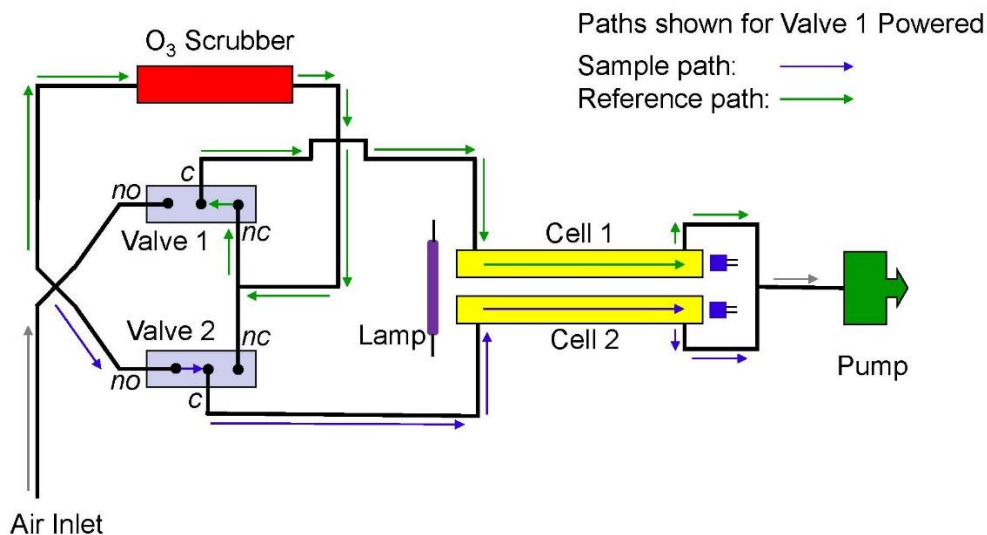

Features

- Quiet, long-life internal air sampling pump
- Low power consumption (~8 watt)
- Internal data logger (EEPROM), logs 16,383 lines of data
- Real-time clock
- Both serial and user-scalable analog voltage outputs (4-20 mA current output optional)
- Flash card memory (SD card) for virtually unlimited, portable data storage
- Three 0-2.5 VDC analog inputs for logging other measurements, such as external temperature, pressure, and humidity
- Convenient user interface to microprocessor, including calibration parameters (gain and zero)
- Selectable measurement time of 2 s or data averaging times of 10 s, 1 min, 5 min and 1 hr (custom averaging times available)
- DewLine™ for elimination of any water vapor interference, a unique feature of 2B Tech instruments
- Dual beam feature allows for heightened precision and improved baseline stability for applications where high spatial resolution is required

Options

- GPS for continuous logging of latitude, longitude, and altitude
- Rechargeable lithium-ion battery provides ~11 hours of continuous operation
- External particle filter
- Serial-to-USB adapter
- 4-20 mA analog current output
- Bluetooth for wireless data transmission
- Cold-weather package for operation to -20°C (pump, lamp heater)
- High-altitude upgrade for operation to 25 km (pressure sensor)
- Extra-long-life, low-temperature internal air pump
- Low-power option for even lower power consumption
- Rack-mount enclosure

2B Technologies, 6800 W. 117th Avenue, Broomfield, Colorado 80020, USA

Specifications

Measurement Principle	UV Absorption at 254 nm; Dual Beam
Federal Equivalent Method (FEM)	Yes, EQOA-0410-190
Linear Dynamic Range	0 to 250 ppm
Resolution	0.1 ppb
Precision (1 σ ; rms noise)	Greater of 1.0 ppb or 2% of reading for 10-s average
Accuracy	Greater of 1.0 ppb or 2% of reading
Limit of Detection (2 σ)	2.0 ppb for 10-s average
NIST-Traceable Calibration	Yes
Measurement Interval	2 s (Data averaging options: 10 s, 1 min, 5 min, 1 hr)
Flow Rate (nominal)	~1.8 Liter/min
Flow Rate Requirement	>1.2 L/min
Baseline Drift	<1 ppb/day; <3 ppb/year
Sensitivity Drift	<1%/day; <3%/year
Measurement Time, Frequency	2 s, 0.5 Hz
Response Time, 100% of Step Change	4 s, 2 points
Measurement and Averaging Times	2 s, 10 s, 1 min, 5 min, 1 hr
Ozone Units	ppb, pphm, ppm, $\mu\text{g m}^{-3}$, mg m^{-3}
Pressure Units	mbar, torr
Temperature Units	$^{\circ}\text{C}$, K
T and P Corrected	Yes
Operating Temperature Range	0 to 50 $^{\circ}\text{C}$ standard; optional -20 to 50 $^{\circ}\text{C}$ with low temperature modifications (pump and lamp heater cold-weather package)
Operating Altitude Range	~0-13.5 km (150-1,013 mbar) standard; optional ~0-25 km (30-1,013 mbar) with upgraded pressure sensor

2B Technologies, 6800 W. 117th Avenue, Broomfield, Colorado 80020, USA

Power Requirement; Supplied by battery or 110/220 VAC Power Pack	11-14 V DC or 120/240 V AC; nominally 650 mA at 12 V; ~8 watt (~7 watt with cell heater unplugged)
Size	3.7H × 8.5W × 11.8L inches (9.5 × 21.5 × 30 cm)
Weight	5.8 lb (2.6 kg); 3.1 lb (1.4 kg) without instrument case
Internal Data Logger Capacity	16,383 lines (2-s fast measurement mode = 9.1 hr; 10-s avg = 1.9 days; 1-min avg = 11 days; 5-min avg = 1.9 mo; 1-hr avg = 1.9 yr)
SD Card Logger Capacity	> 2 GB (> 5-year capacity for 10-s averaging mode)
Analog Inputs for Internal Logging of Other Instruments	3 Analog Inputs, 0-2.5 V; for example, could log external T, P, and RH
Data Outputs	RS232, 0-2.5 V Analog, LCD Display (Optional 4-20 mA Current; request quote)
Data Transfer Baud Rates	2400, 4800, 19200
Output Ranges	User-Defined Scaling Factor in Menu
DewLine™	Yes
Quiet, Long-Life Internal Air Pump	Yes
Flow Meter	Yes
Options	Battery; External Particle Filter; GPS; Bluetooth; Serial-to-USB Adapter; 4-20 mA Current Output; Cold-Weather Package, -20 to 50°C (pump, lamp heater); High-Altitude Upgrade, ~0-25 km (pressure sensor); Extra-Long-Life, Low-Temperature Internal Air Pump; Low-Power Option; Rack-Mount Case

System Includes

- Model 205 Ozone Monitor
- Quiet, Long-Life Internal Air Pump
- AC Power Adapter (100-240 VAC to 12 VDC) with Country-Specific Plug
- Zeroing Cartridge
- Flash Card Memory for virtually unlimited, portable data storage
- SD Card (> 2 GB) and SD Card Reader
- Operation Manual on USB Stick
- Calibration Data and NIST-Traceable Calibration Certificate
- Instrument Birth Certificate
- One-Year Warranty

Phone: +1(303)273-0559, Fax: +1(303)-277-1812, www.twobtech.com
 2B Technologies, 6800 W. 117th Avenue, Broomfield, Colorado 80020, USA