

## WIRELESS WMO PRECISION MICRO-WEATHER STATION

Freedom to measure anywhere with WMO accuracy

WMO precision for temperature and humidity

Wireless & solar powered  
Robust & impact resistant



### Professional WMO precision

Temperature, humidity, dew point, frost point and rain measurement

### Stable long-term accuracy

3-in-1 sensor tip housed inside the helical MeteoShield® Pro offers long-term stability and low uncertainty of measurement

### Accurate in all climates & weather

Housed in a MeteoShield® Pro for accurate measurement in all weather conditions and a high level of protection to the sensors

### Easy calibration procedure

Traceability is assured by a removable sensor tip which is interchangeable and can be easily calibrated with a calibration adapter or replaced

### View & export live weather data

allMeteo® Web portal enables easy world-wide view of your weather station data including data export, API data access and live data view. It also offers the ability to manage your fleet of weather stations.

### MeteoHelix® micro weather stations

Exceeding WMO accuracy standards has never been so easy and affordable.

Designed for measurement precision and ease of use, MeteoHelix IoT weather stations offer professional research grade accuracy meeting World Meteorological Organization standards.

Unique measurement properties of the patented double-helix design make this weather station highly **resistant to long-term sensor drift** and sensor measurement errors from the sun and other environmental factors.

This helical micro-weather station is the perfect choice for climate research in tough measurement environments.

Available in SigFox and LoRaWAN.

### allMeteo® portal for data display and configuration.

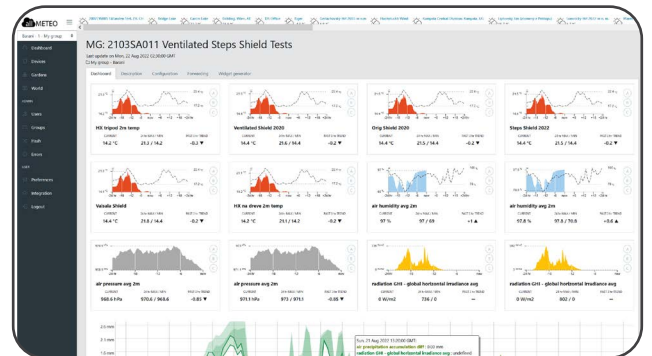

Type	Accuracy	Stability	Resolution	Measuring range	Operating range	Response*	Meets WMO
Temperature	±0.1 °C (0 to 65 °C) ±0.2 °C (-45 to 65 °C)	<0.03 °C per year	0.01 °C	-45 °C...65 °C	With cold weather battery -45 °C...65 °C or -33 °C	5-30 s	yes
Relative humidity	±1.5 %RH @ 0-65 °C hysteresis ±0.8 %	<0.2 %RH per year	0.2 % RH	0...100 % RH	0...100 % RH	8-40 s	yes
Dew point / Frost point	(calculated)	-	0.1 °C	-45 °C...65 °C	-40 °C...65 °C (battery limitation)	8-40 s	yes
Solar irradiation	5 % of daily total	-0.5 % per year	1 W/m <sup>2</sup>	0...2000 W/m <sup>2</sup>	-40 °C...65 °C (battery limitation)	< 1 s	yes
Atmospheric pressure	±0.5 hPa (0 to 55 °C) (750 - 1100hPa)	0.5 hPa per year	0.02 hPa (mbar)	300...1100 hPa	300...1300 hPa	0.1 s	yes
Rain (reed switch input)	With MeteoRain 200 Compact, ±2% @ 0.2 mm	Rain gauge dependent	0.1...0.5 mm Rain gauge dependent	4915 mm per hour @ 0.2 mm resolution	Rain gauge dependent	Rain rates up to 600mm/hr	yes

Sampling rate is 10 seconds per WMO requirements.

\* T63 % sensor response time listed is with a filter cap. Response time with filter cap will vary based on cap porosity, material and fluid (air) flow.

In applications where sensors are used in wet, dirty and dusty environments, we recommend regular inspection of filter cap cleanliness to maintain long term accuracy. Inspection interval should be determined by application and user experience in their application environment.

## RUGGEDNESS AND PRECISION FOR THE PROFESSIONALS, EASY TO USE FOREVERYONE.

Electrical specifications of sensor		
Wireless communication	Available versions: Sigfox, LoRaWAN, (NB-IoT coming soon)	
Supply voltage	Solar powered with internal Li Ion battery for 4+ months of operation without sun	
Power on/off	Magnetically activated on/off switch located in sensor head	
External connections	4 meter cable interface for pulse output rain gauge sensors	
Environmental rating of sensor		
Operating temperature & humidity	-33 °C to +65 °C or (-45 °C to +65 °C with cold winter battery)	0 % to 100 % RH
IP – Protection rating	IP65W (DIN 40050) Protected from dust and weather	
General specifications		
Dimensions	Diameter = 170 mm, Height = 226 mm	
Weight (mass)	1.2 kg (2.0 kg including stainless steel holder)	

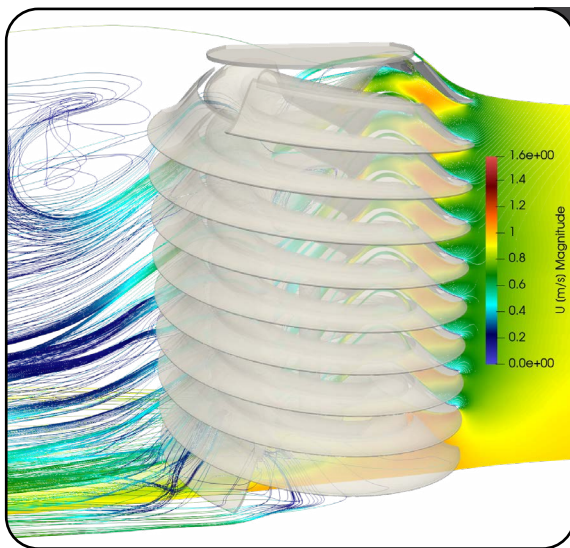

## A weather station inside the MeteoShield® Pro<sup>Gen3</sup>

Naturally ventilated helical solar shield/screen. **Double-Helix shape eliminates** temperature errors from solar radiation more effectively than conventional multi-plate shields while offering unsurpassed **protection from the sun, dirt, rain, snow, sand & dust**. Double-helix increases clean air flow and rejects dirt particles away from the sensor, while keeping sensors cleaner than traditional multi-plate and fan aspirated shields.

## Benefits of the MeteoShield's double-helix shape

Helical radiation shield shape ventilates better than multi-plate radiation shields while maintaining better temperature sensor protection from dirt, sand, dust, rain, snow and ice.

### BENEFITS:

1. Extend sensor life.
2. Increase precision and long-term measurement stability
3. More accurate than any other weather station in high-reflectivity environments such as over snow, water, pavement and in cities in Smart-City applications.

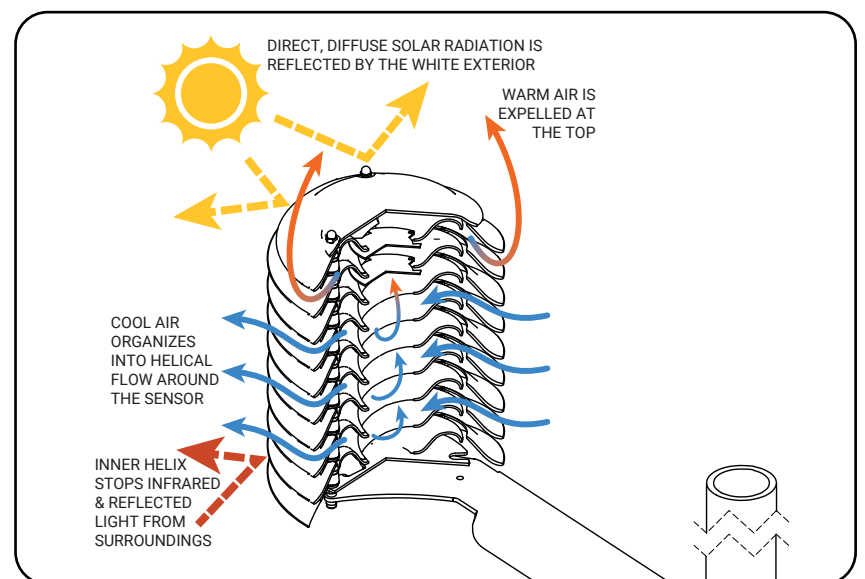
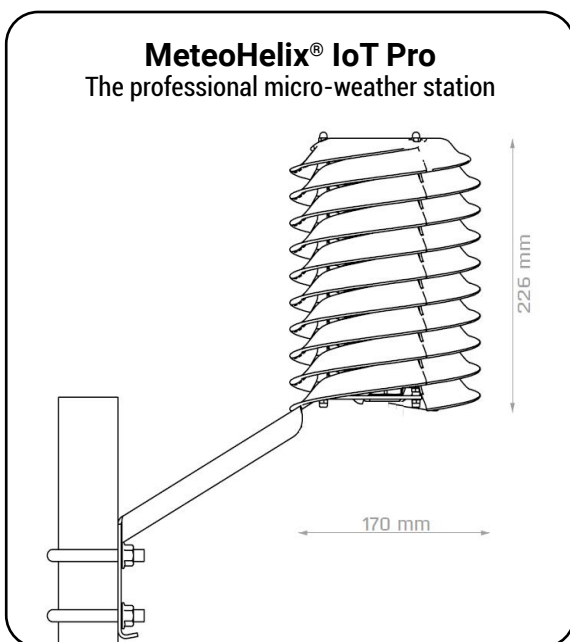

Reach your gold standard of measurement with BARANI DESIGN ISO:9001 quality